

PRESS RELEASE

Date: 5th August 2005

Wespack Extended Range of Phase Control Thyristors



Westcode Semiconductors Limited (An IXYS company) announces the launch of a further two new devices to its revolutionary range of contemporarily designed Wespack low profile, fully hermetic press-pack capsule devices.

The second wave of new devices to become available are **N1651QK200** and **N1806QK120**. These revolutionary new devices have current ratings of 1651A and 1806A, voltage ratings of up to 2200V and 1800V respectively and are encapsulated in a hermetic, 38mm (1½ ") diameter pole face, press-pack package.

Wespack offers the maximum current rating and lowest thermal resistance for weight and volume without compromising on quality and reliability. A Wespack phase control thyristor from IXYS offers a cost effective and space saving alternative to conventional designs - More power, less package. The Wespack outline is capable of meeting the requirements of EN50124-1:2001, Part 1 [Basic requirements – clearances and creepage distances for all electrical and electronic equipment] when appropriately applied, and offers over three times the power to weight ratio of a traditional **TO-200** style housing of the same current rating.

The N1651QK200 and N1806QK120 weigh in at only 200 grams (0.44 lbs) compared to **1kg (2.2 lbs)** for a similarly rated device in a **TO 200** type outline. Saving **4.4kg (9.68 lbs)** in a typical 3 phase bridge.

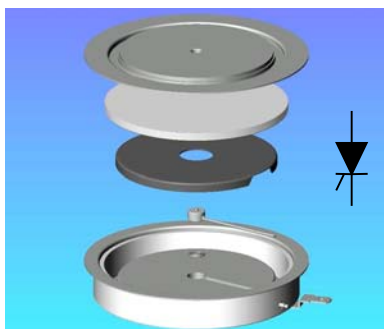

The internal build of the new Wespack package has been reversed from that used in the traditional **TO-200** style housing, with the weld flange on the anode side, simplifying the internal construction.

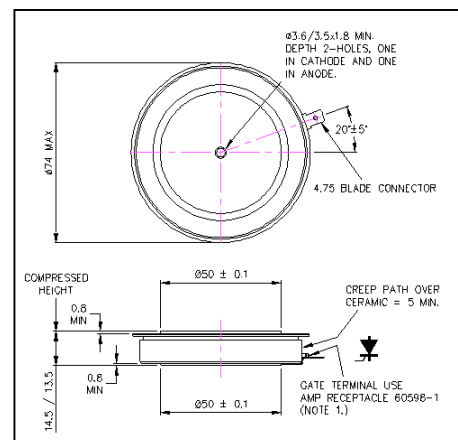

The new “Wespack” thyristor slimline package is 14mm (0.55”) thick, optimising the thermal path from silicon to cooling system.

The hermetic ceramic package is suitable for all cooling options including forced air, liquid, plus total immersion systems such as oil and fluoroinert. The lower profile of the package allows for a much more

compact subassembly increasing realisable power for a given volume and weight. In forced air systems, the reduced component height allows the cooling fins to be brought closer together, thus reducing wasted air flow and increasing the flow where it is need in the fins.

The N1651QK200 and N1806QK120 represent the second phase in the new product range from IXYS. Further introductions will include the addition of a 1400V device to join the recently launched N2367MK200 and N2593MK120 in the same 50mm (2") pole face housing. Followed by further devices with a package size of 68mm (2.7") diameter pole face later this year. These additional devices will also be available in three voltage classes; 1400V, 1800V and 2200V and will offer the same slimline 14mm thick profile.

Wespack thyristors are suited to all phase control applications such as soft starts, industrial drives and controls, wind power converters, electrochemical power supplies, and welding.

Data sheets are available on www.westcode.com. For a quotation please contact us at (email: WSL.sales@westcode.com) or telephone: +44 (0)1249 444524.

Author: F J Wakeman – Marketing & Evaluation Manager
Company: Westcode Semiconductors Ltd, Langley Park Way, Langley Park, Chippenham, Wiltshire SN15 1GE
England UK
Contact Details: Tel: +44 (0)1249 444524
Fax: +44 (0)1249 659448
Email: frank.wakeman@westcode.com